

## Measuring transducers

### E 400 Analog/puls transducers for e.g. energy

E 400 convert a DC-signal to a proportional pulse frequency. It is used e.g. with a power transducer for making energy pulses.

The transducers have transistor and/or relay output that can be connected to a pulse counter, energy collecting system or other measuring equipments. There are two types of transistor outputs available. Type 01 internally powered is not galvanically separated 24 V level. Type 02 potential free via opto coupler galvanically separated for external power.

The transducers in plastic case are mounted directly on profiled bar 35EN50022. Connection to selfopening clamps for max 6 mm<sup>2</sup> wires. Transducers for mounting in 19" racks can be delivered in different application types (see special leaflet). The rack modules are 8 TE wide and in a 19" rack is place for 10 modules.

The transducers are manufactured according to IEC 688.

#### Order facts:

Enclosed for mounting on profiled bar 35 EN 50022	19" rack modul (wide 8 TE)	Output
Typ	Typ	
E 400L-01	E 400R-01	Internally powered transistor
E 400L-02	E 400R-02	Externally powered transistor
E 400L-03	E 400R-03	Relay + internally powered transistor
E 400L-04	E 400R-04	Relay + externally powered transistor

#### Order form:

Measuring transducer E 400L-03

Input 0-20 mA

Output relay + internally powered transistor 0-1200 imp/h

Power supply 110 VAC

Enclosed for mounting on profiled bar 35 EN 50022

E400-FA



E400-FB

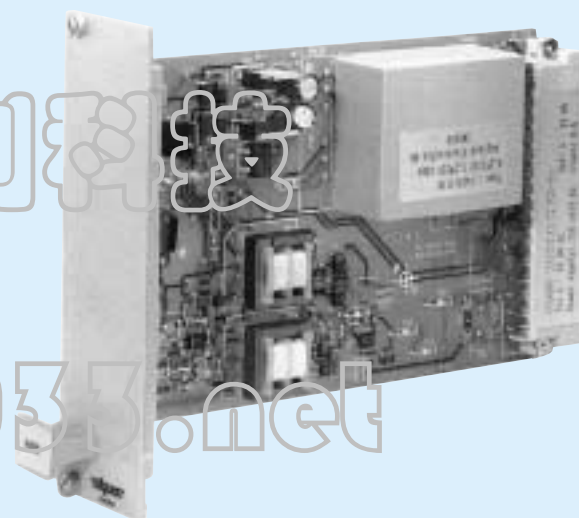

## Technical data

### Input

Input current 0-5, 0-10, 0-20, 4-20 mA

Load approx. 1 V

Input voltage 0-10 V

Load approx. 100 µA

### Output

Output possibilities see table above

Pulse frequency any value between 0-10 imp/h and 0-54000 imp/h with relay max. 3600 imp/h

Pulse duration min 100 ms

Relay type -03, -04 potential free closing contact 4 A, 250 VAC 0,4 A, 110 VDC

Transistor type -01, -03 open collector, active high internally powered not galvanically separated voltage level 24 V max current 100 mA

Transistor type -02, -04 opto isolated open collector for external powering max 60 V, 50mA

## General data

Accuracy ± 0,2%

Linearity error < 0,1%

Temperature influence < 0,1% / 10°C

Temperature range -25...+60 °C operation -40...+70 °C storage

Test voltage 3,7 kV, 50 Hz, 1 min

Power supply 24, 110, 230 VAC ±15%, 47-70 Hz, ca 2 VA 24-130 VDC ± 20%, ca 2,5 W

Weight 0,4 kg

### Options on request

## Standards

General standards for measuring transducers EN 60688, IEC 688

EMC emission EN 50081-2 immunity EN 50082-2 \*

Safety EN 61010-1, IEC 1010-1

Inputs overvoltage cat III

Outputs overvoltage cat II

Pollution degree 2

\*) At certain frequencies can minor deviations from class accuracy occur during the disturbance

## Design

The input signal is adapted to a suitable level in the input amplifier. This signal is converted to a proportional frequency in the analog/frequency converter. The converter is quartz stabilized and gives a very accurate value. In the frequency divider the signal is divided to a suitable frequency and is led to the output which either is a potential free relay or a transistor output.

The AC power supply comes from a transformer that gives a galvanic separation. Those parts that need separate power get it via a rectifying stage. The DC power comes from a switched unit that gives galvanic separation and covers the span from 24 to 130 VDC.

E400BE

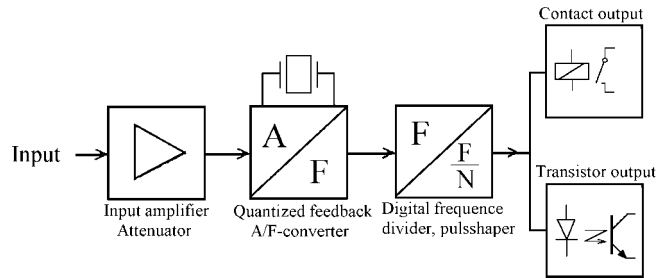

## Connecting diagrams

### E 400L

E400LE

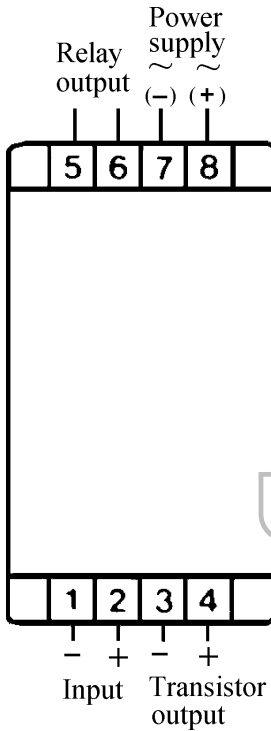

### E 400R

E400RE

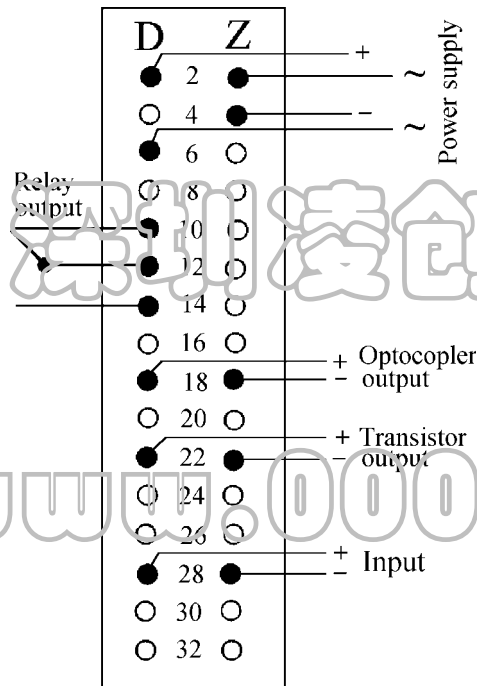

### E 400 outputs

E400RKE

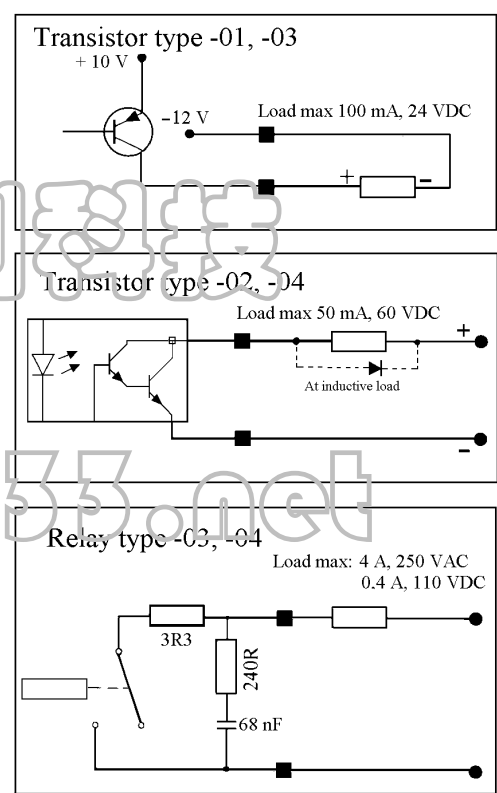

## Dimensions (mm)

### E 400L

MATOMVE

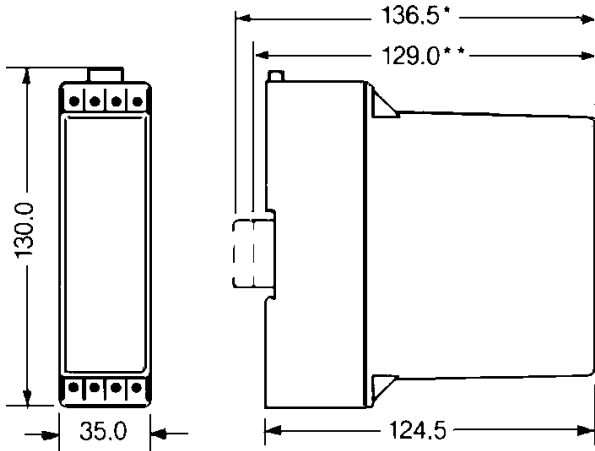

### E 400R

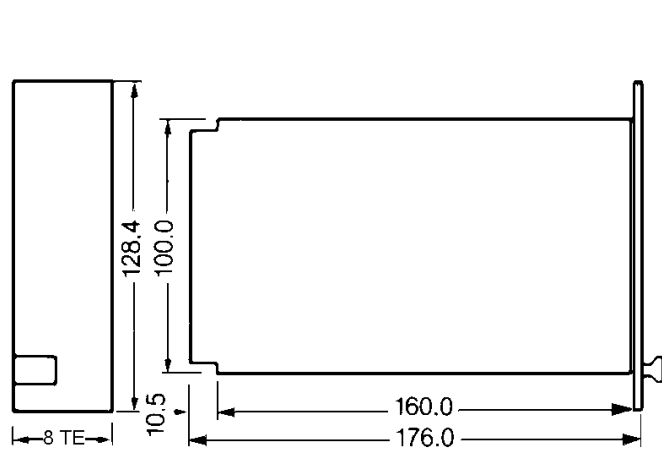

\*) Profile bar 35 EN 50022, hight 15 mm

\*\*) Profile bar 35 EN 50022, hight 7,5 mm